

A background image showing a splash of water falling from the top and creating ripples and bubbles at the bottom. The water is clear and the background is a light, hazy blue.

Rain/Mains Water Controllers

Section 8

Common Features

The unique MATElec Rain/Mains Water Controller is designed to provide a continuous supply of water for a variety of uses, whilst prioritising and maximising the usage of Rain Water.

The system comprises a Controller, a unique Valve and a Liquid Level Switch. The controller not only monitors the level of stored Rain Water, switching the valve accordingly, but also provides a switched output for the control of power to a pressure pumping system.

If Rain Water becomes available, the valve through which Mains Water is being supplied, is automatically pulsed closed by the controller, and at the same time, the 240Vac pump output contacts are energised.

In the event of either 'Rain Water Depletion' or 'Power Failure' the controller will immediately pulse the valve open, and de-energises the pump output contacts.

The controller has a 'System Test' function which, if initiated, changes the status of the system to enable the operator to check pump and valve function at the press of a button.

Features include:

- Unlimited pump options, Single or Three Phase, above ground or submersible
- Compatible with an entire range of high flow, low 'head loss' valves
- No pressure reducing valves
- No continuously actuated solenoid valves
- Test Button - Provides change of system status, including pump and valve switching
- Indicator Lights provide 'power' and 'valve' status information
- Pump protection feature - If Rain Water is depleted, switching of pump output isolates power to pressure pump system
- Controller can be situated up to 50m from storage tank
- Ideal for Industrial, Commercial and/or Domestic applications

The Range

Product Code	Pump Voltage	Contactor / Overload	Max Current	Enclosure Type
FPC-12720	240Vac	None	6Amps	Poly
FPC-12721	240Vac	None	6Amps	Poly
FPC-12724-A	240Vac	Yes	2.5 - 4Amps	103 *
FPC-12724-B	240Vac	Yes	4 - 6Amps	103 *
FPC-12724-C	240Vac	Yes	6 - 9Amps	103 *
FPC-12724-D	240Vac	Yes	9 - 13Amps	103 *
FPC-12725-A	415Vac	Yes	2.5 - 4Amps	103 *
FPC-12725-B	415Vac	Yes	4 - 6Amps	103 *
FPC-12725-C	415Vac	Yes	6 - 9Amps	103 *
FPC-12725-D	415Vac	Yes	9 - 13Amps	103 *

* Please Note: Refer to Section 5 of this document for Enclosure Specifications

Rain/Mains Water Controllers

Controller Descriptions



Product Code	Product Description
FPC-12720 'OEM Version'	Housed in a robust, weatherproof, polycarbonate enclosure, this unit is ideal for OEMs who require a control system to compliment a pressure pumping system. The unit is supplied without any cable penetrations providing the installer complete installation versatility.
FPC-12721 'Quick Plug' DIY Version	Sharing the same enclosure as the 'OEM Version', the DIY model has been pre-fitted with sockets for the pump, valve and float switch connections. All these connections differ from each other making it impossible to incorrectly connect the unit. This is an excellent feature for installations where appropriately qualified tradesman are not available.
FPC-12724 & FPC-12725 Industrial/ Commercial Version	For Industrial and Commercial applications such as playing fields, golf courses and large commercial properties, where a 'high flow' system is required, standard controllers for both Heavy Duty 1 Phase 240Vac and 3 Phase 415Vac pumps are available. Housed in a lockable metal enclosure, the FPC-12724 and FPC-12725 controllers are equipped with contactors and overloads compatible for pumps (1Ph or 3Ph) rated up to 13amps Full Load current.

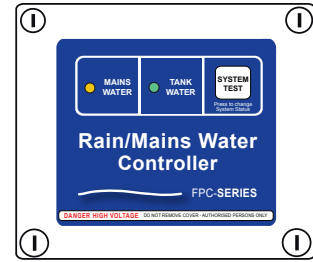

Dimensions - 145mm (h) x 85mm (d) x 170mm (w)

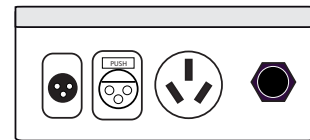

Float Switch Valve Pressure Controller Power Lead

Dimensions - 145mm (h) x 85mm (d) x 170mm (w)

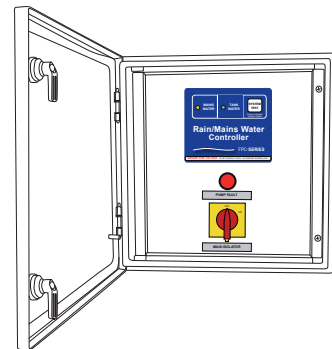

Dimensions - 400mm (h) x 300mm (w) x 200mm (d)

Schematic

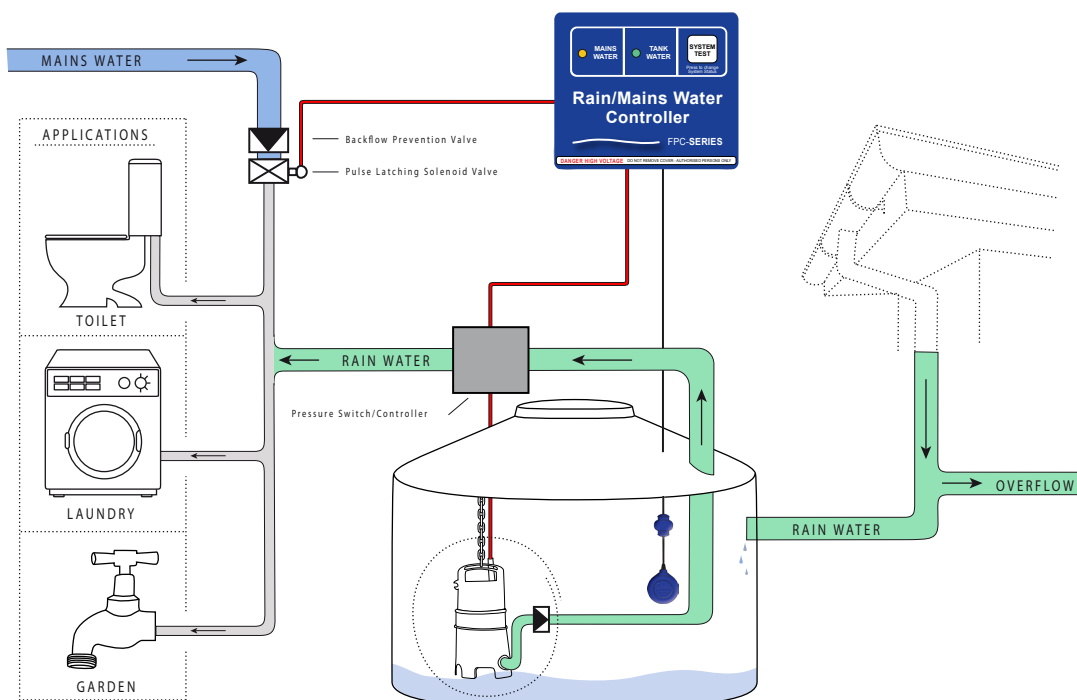

Model FPC-12724 1 Phase

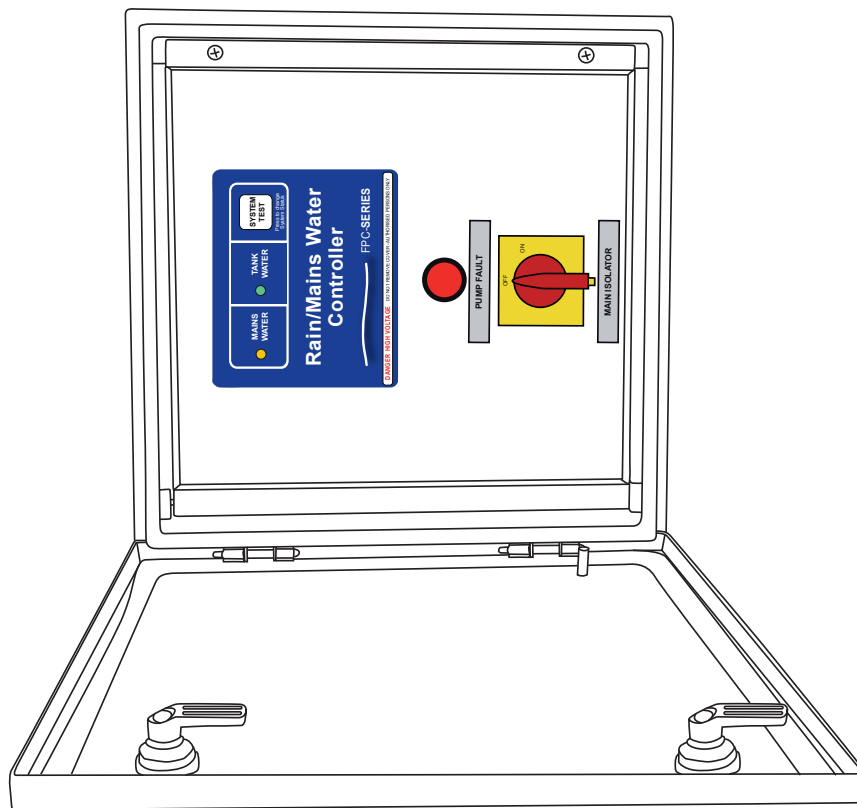
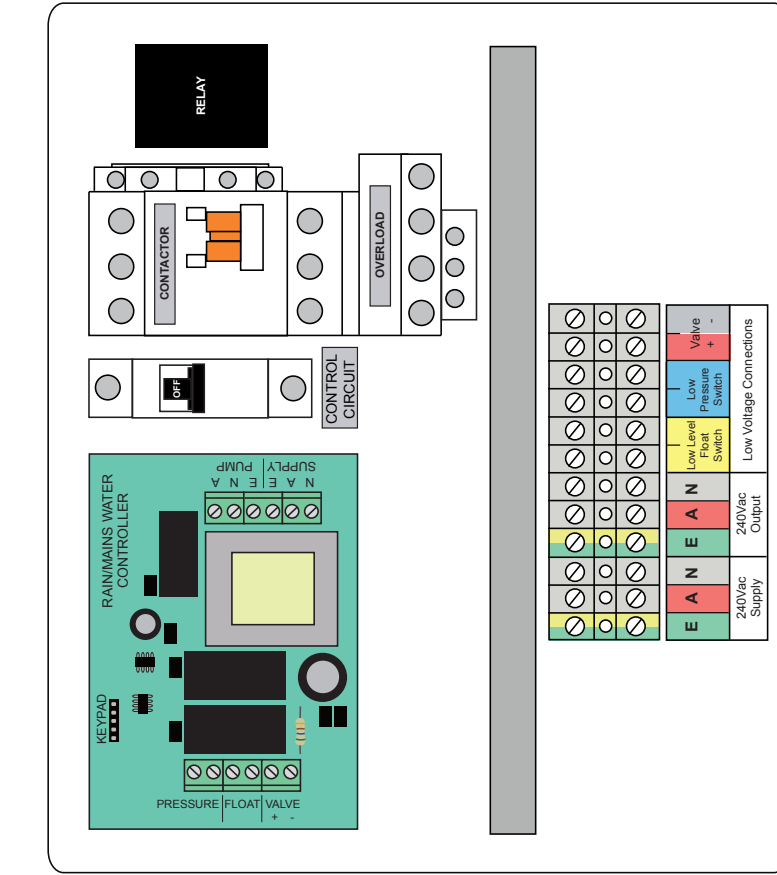

Internal Door

Component Layout

Rain/Mains Water Controllers Wiring Diagram



FPC-12724 1 Phase

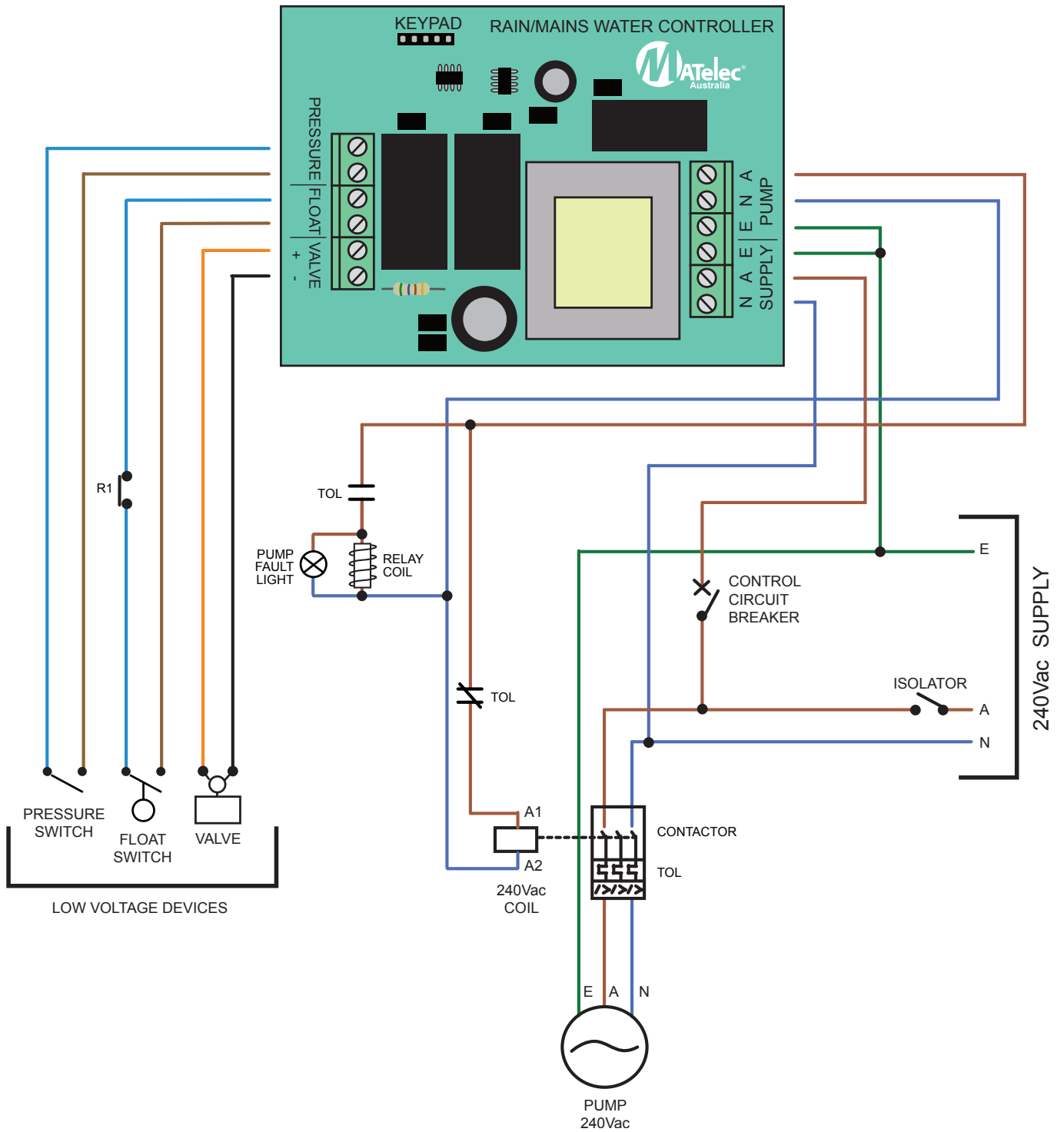

Rain/Mains Water Controllers Component Layout



Model FPC-12725 3 Phase

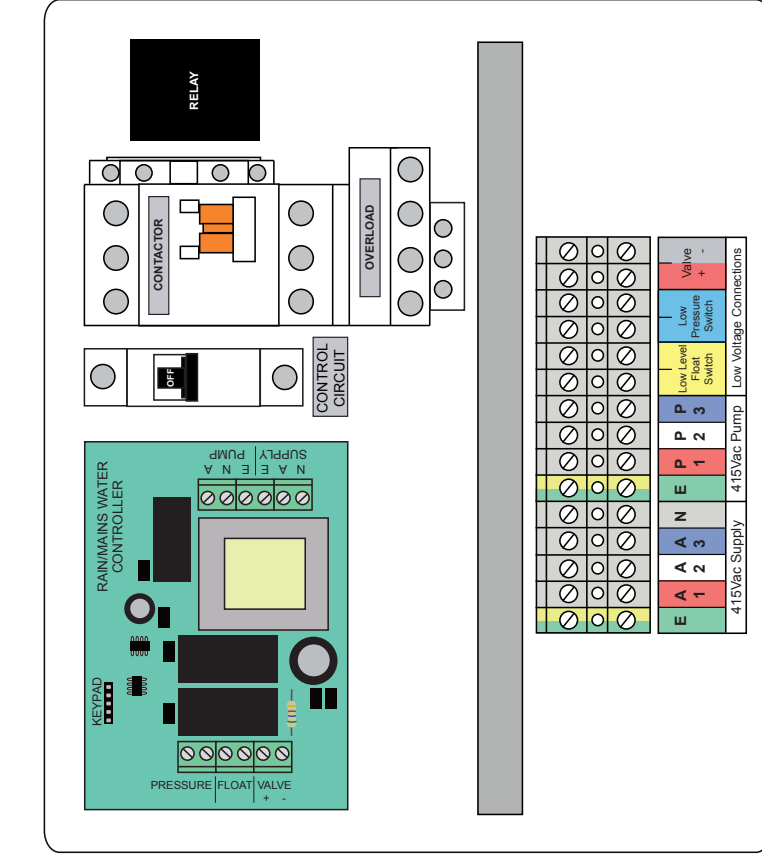

Component Layout
Enclosure 103
See Section 5 for Enclosure details

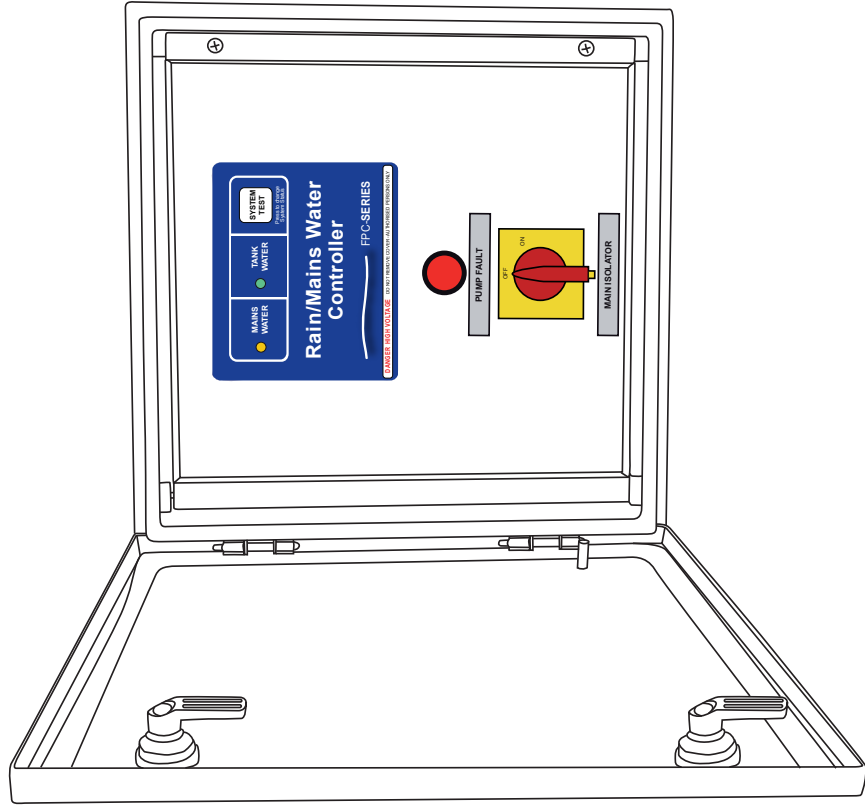

Internal Door

Rain/Mains Water Controllers Wiring Diagram



FPC-12725 3 Phase

